

Feb. 18, 1941.

B. G. TREW

2,232,151

MULTIPLE SAXOPHONE UNIT

Filed Nov. 10, 1938

4 Sheets-Sheet 1

Fig. 1.

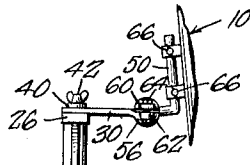
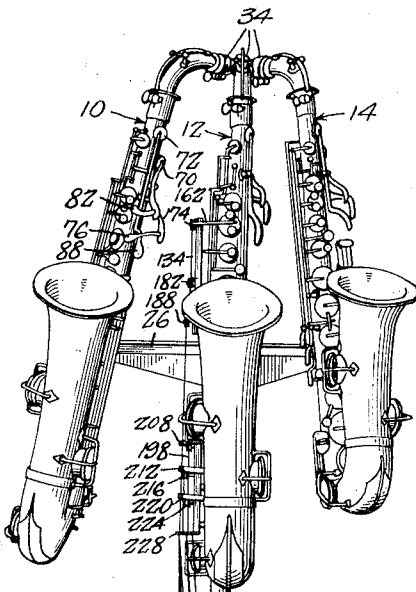

Fig. 10.

Fig. 11.

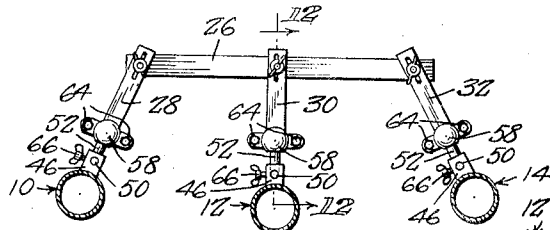
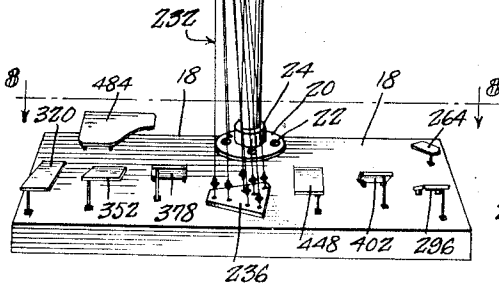
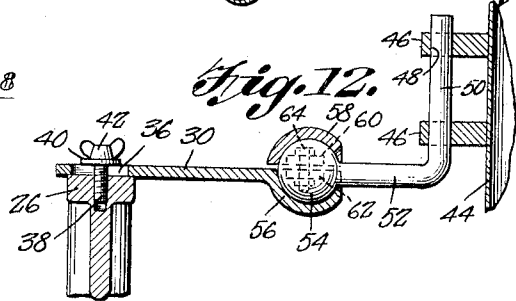

Fig. 12.



Feb. 18, 1941.

B. G. TREW

2,232,151

MULTIPLE SAXOPHONE UNIT

Filed Nov. 10, 1938

4 Sheets-Sheet 2

Fig. 2.

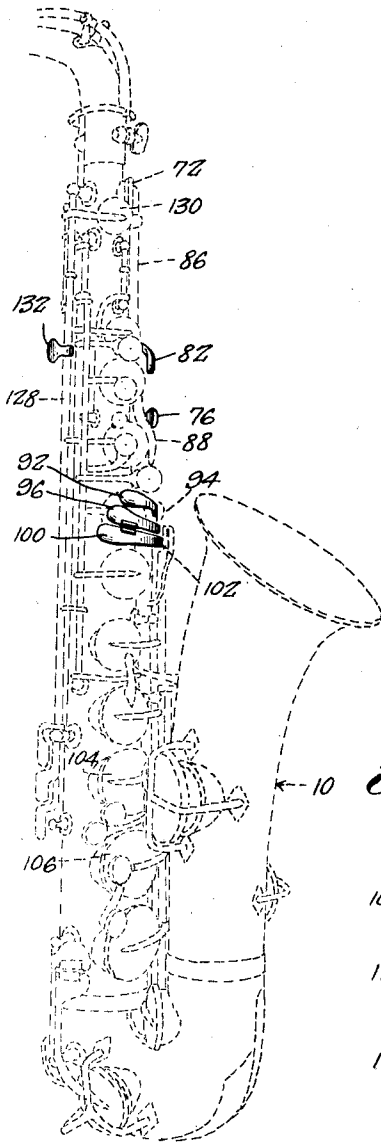

Fig. 3.

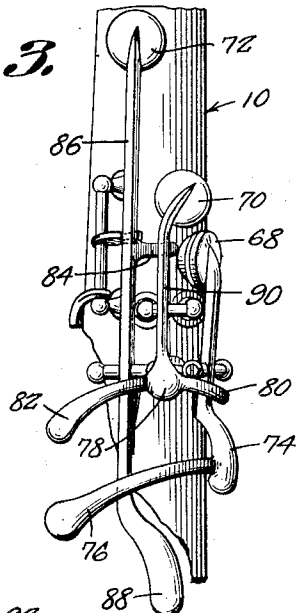
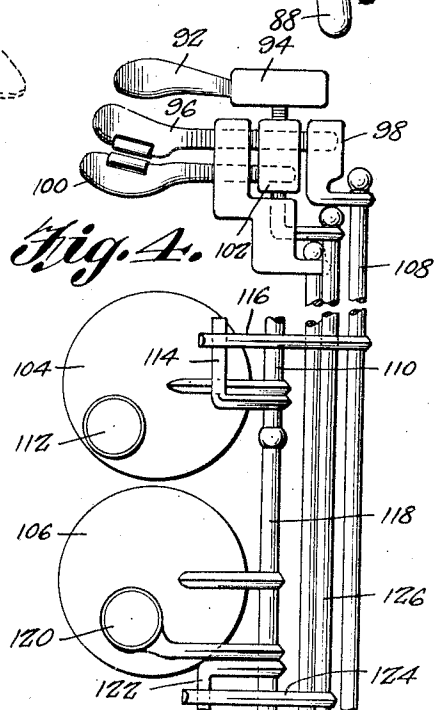

Fig. 4.



P. Hickey
WITNESS

Bill G. Trew, INVENTOR
BY *Victor J. Evans & Co.*
ATTORNEYS

Feb. 18, 1941.

B. G. TREW

2,232,151

MULTIPLE SAXOPHONE UNIT

Filed Nov. 10, 1938

4 Sheets-Sheet 3

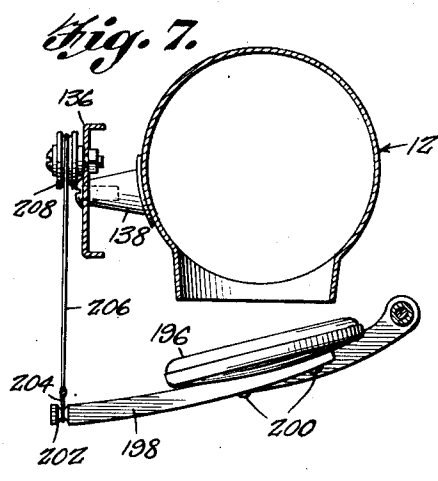
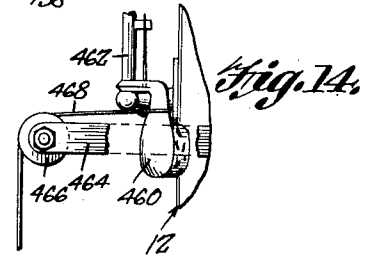
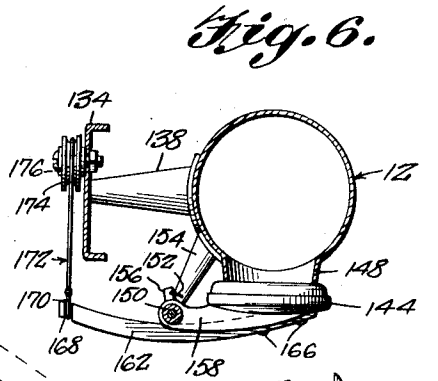
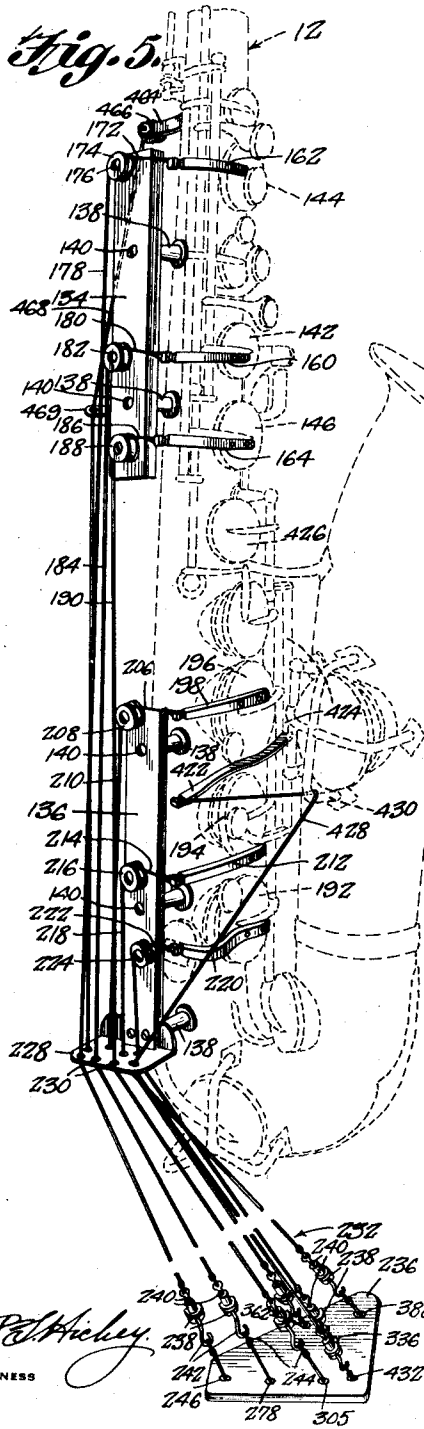

W. H. Hickey
WITNESS

Bill G. Trew, INVENTOR
BY *Victor J. Evans & Co.* ATTORNEYS

Feb. 18, 1941.

B. G. TREW

2,232,151

MULTIPLE SAXOPHONE UNIT

Filed Nov. 10, 1938

4 Sheets-Sheet 4

Fig. 8.

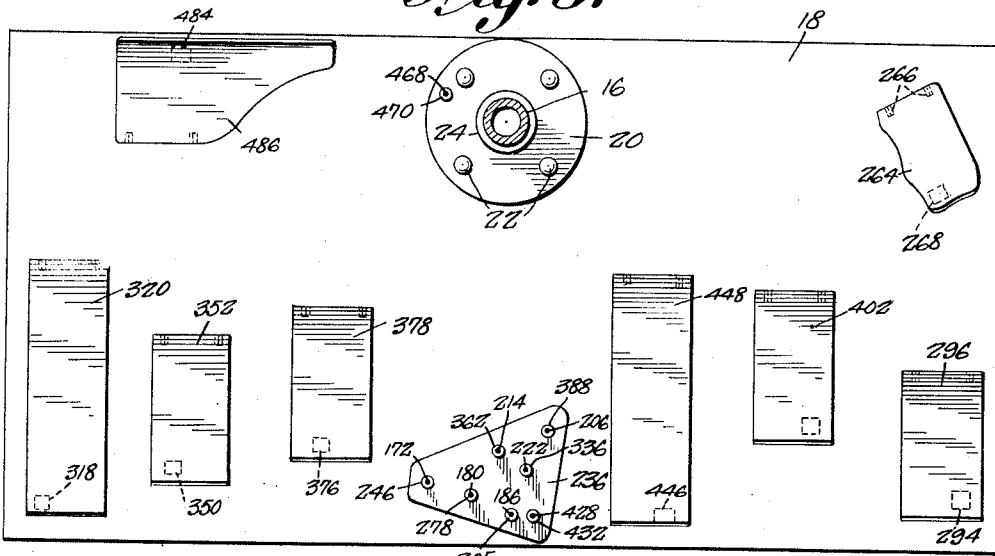

Fig. 9.

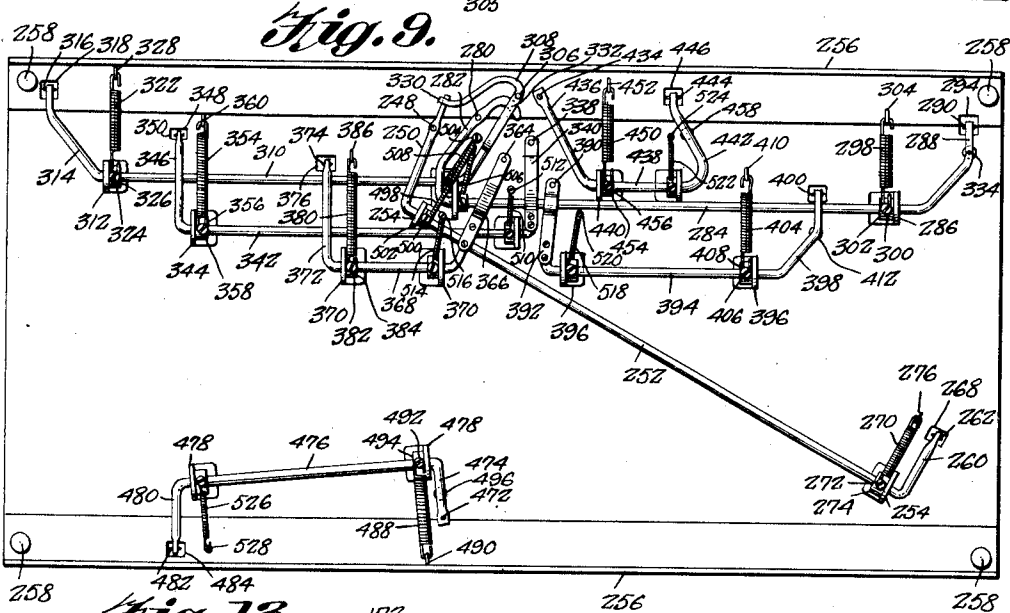
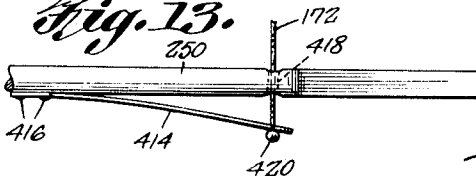

Fig. 13.



Bill G. Trew,

INVENTOR

BY Victor J. Evans & Co.

ATTORNEYS

P. H. Ashley.
WITNESS

UNITED STATES PATENT OFFICE

2,232,151

MULTIPLE SAXOPHONE UNIT

Bill G. Trew, Steubenville, Ohio

Application November 10, 1938, Serial No. 239,882

4 Claims. (Cl. 84—385)

My invention relates to musical instruments, and has among its objects and advantages the provision of an improved saxophone unit.

5 An object of my invention is to provide novel means for grouping a plurality of saxophones in such manner as to facilitate playing thereof by one player. The saxophones are grouped on a suitable support with two saxophones arranged for finger manipulation of the keys thereof, with 10 the other saxophone provided with novel foot operated means for key manipulation.

In the accompanying drawings:

Figure 1 is a perspective view illustrating three saxophones associated with a common base;

15 Figure 2 is a perspective view of the greater portion of one of the saxophones illustrating novel key operating means associated therewith;

Figure 3 is an enlarged detail view of some of the key operating means associated with the saxophone of Figure 2;

20 Figure 4 is an enlarged detail view of other key operating means associated with the saxophone of Figure 2;

Figure 5 is a perspective view of the greater portion of a saxophone illustrating the foot operated key means associated therewith;

Figure 6 is a transverse sectional view of the saxophone of Figure 5 illustrating the key action associated with one of the keys;

30 Figure 7 is a similar view illustrating another key action associated with the saxophone of Figure 5;

Figure 8 is a view taken from the position indicated by line 8—8 of Figure 1;

35 Figure 9 is a bottom plan view of the base structure of Figure 8;

Figure 10 is a view of the saxophone standard mounted on the base;

40 Figure 11 is a view illustrating the manner in which the saxophones are mounted on the standard;

Figure 12 is an enlarged sectional view along the line 12—12 of Figure 11;

45 Figure 13 is a fragmentary detail view of tensioning means for foot operated keys; and

Figure 14 is a detail view of a portion of the foot operated means for manipulating the octave key.

50 In the embodiment selected to illustrate my invention, Figure 1 illustrates three saxophones 10, 12 and 14 as being grouped for playing by one player. The saxophones are mounted on a standard 16 attached to a base 18 through the medium of a flange 20 secured to the base by 55 screws 22. Flange 20 includes a socket 24 into

which the lower end of the standard 16 is pressed to be supported in an upright position. Standard 16 may comprise tubular material for the sake of lightness and suitably ornamented.

In Figures 1, 10, 11 and 12 I illustrate the 5 manner in which the saxophones are connected with the standard. To the upper end of the standard 16 I secure a bar 26 intermediate its ends. Bar 26 is arranged at right angles to the standard 16 and carries arms 28, 30 and 32 to 10 which the saxophones 10, 12 and 14, respectively, are connected to be supported in such manner as to bring their mouthpieces 34 into simultaneous playing relation. Arms 28, 30 and 32 are identical in construction and operation so that the 15 description of one will apply to all. Figure 12 illustrates the arm 30 which arm is slotted at 36 for the reception of a screw 38 threaded into the bar 26. A washer 40 is positioned between the head 42 of the screw 38 and the arm 30. Thus 20 the arm 30 may be shifted longitudinally or rotated about the axis of the screw 38 to secure precise alignment of the arm. Tightening of the screw 38 firmly secures the arm 30 in the desired position. 25

To the wall 44 of the saxophone 12 I secure two spaced ears 46 which are bored at 48 for the reception of the vertical stem 50 of the horizontal rod 52 provided with a ball 54. Ball 54 is located inside the socket section 56 at one end of the 30 arm 30 and within the socket section 58 in the nature of a cap having flanges 60 cooperating with flanges 62 on the socket section 56 for consummating a clamped connection with the ball 54. Flanges 60 and 62 are provided with aligned 35 openings for the reception of bolts 64 through the medium of which the socket sections 56 and 58 are brought into pressure relation with the ball 54. Both of the ears 46 may be provided with set 40 screws 66 to secure the stem 50 against relative rotary movement as well as to secure the saxophone associated with that stem in different positions of adjustment vertically. It will thus be seen that the saxophone 12 may be adjusted 45 through rotation of the ball 54 in the associated socket and that the saxophone may be adjusted about the stem 50 as an axis, in addition to being adjustable vertically of the stem. Thus I provide means for securing precise positioning of the saxophone. Arms 30 may be shifted to various 50 angular relations to secure proper spacing between the saxophones 10, 12 and 14.

Saxophone 12 is equipped for foot operation, while saxophone 10 is provided with means to facilitate manipulation of keys by the right hand 55

which are manipulated by the left hand in standard equipment. No changes are made in the saxophone 14. With respect to saxophone 10, high D, Eb and high F keys indicated at 68, 70 and 72, respectively, in Figure 3 are provided with actuating means adapted for manipulation by the right hand. To the D key button 74 I connect an arm 76 which extends about the instrument sufficiently far to bring the key within reach of the right hand. Eb button 78 is provided with arms 80 and 82, with the arm 82 arranged for right hand manipulation. An arm 84 is connected with the bar 86 manipulated through the medium of the high F button 88. Arm 76 extends over the bar 86, while arms 80 and 82 extend over the button 74 and the bar 86, respectively. Arm 84 extends underneath the bar 86 to which the button 78 is connected.

When a high F tone is played, all three keys 68, 70 and 72 must be open. Normally these keys remain closed. Opening of the three keys may be accomplished with the use of but one finger by pressing on the button 88. Such pressure on the button 88 moves the arm 84 upwardly for lifting the key 70 simultaneously with elevation of the key F. As key 70 is elevated, the arm 80 exerts pressure on the button 74 for simultaneously opening the key 68. When a high Eb tone is played, both keys 68 and 70 must be opened. Exerting pressure on the finger 82 will open the key 70 and simultaneously open key 68 because of the arm 80 which presses down on the button 74. Arms 76 and 82 are spaced from the bar 86 sufficiently far to be in the clear of the bar in all positions of the keys 68 and 70 when manipulated through the medium of the arm 82. It will thus be seen that keys 68, 70 and 72 may be manipulated by the right hand, rather than by the left as is conventional practice in standard saxophones.

In standard saxophones, the player can go no lower than the tone G through the use of one hand. In order to secure tones below G with one hand only, I add an arm 92 to the G# button 94 and an arm 96 to the C# button 98. An arm 100 is attached to the B button 102. The lower F and E keys are indicated at 104 and 106, respectively. Keys F and E are located far down on the instrument. Arms 92, 96 and 100 are arranged within playing range of the buttons 76, 82 and 88. C# button 98 is connected with a rotary shaft 108 for operating the C# key (not shown). I utilize shaft 108 for operating the low F key 104. Key 104 is connected with a rotary shaft 110 and is conventionally depressed through the medium of the button 112. To the shaft 110 I connect an arm 114 which lies underneath an arm 116 connected with the shaft 108, so that pressure on the arm 96 will move the arm 116 downwardly on the arm 114 for closing the key 104. Thus the key 104, which is located at a considerable distance down the instrument, may be manipulated through the arm 96 by the little finger of the right hand arranged within playing range of the buttons 76, 82, 88 and the arm 92. Low E key 106 is connected with a rotary shaft 118 and is ordinarily manipulated through the medium of the button 120. To the shaft 118 I connect an arm 122 which lies underneath an arm 124 connected with the rotary shaft 126 operatively connected with the button 102. Thus the key 106 may be closed by exerting pressure on the arm 100.

To the conventional shaft 128, which operates the high E key 130, I connect a button 132 which

renders the key operable from a position high up the instrument. As a rule, this key is operated with the second hand located near the bottom of the instrument. Button 132 renders the key accessible to the right hand.

Referring to Figure 5, saxophone 12 is provided with two parallel channel-like supports 134 and 136 spaced longitudinally of the saxophone. These supports are made secure to posts 138 welded or otherwise secured to the saxophone at their inner ends and connected with the supports at their outer ends through the medium of screws 140. Support 134 is associated with the A, B and G keys 142, 144 and 146, respectively. Ordinarily, these keys are normally open in conventional saxophones. In the instant case I arrange the keys so as to be normally closed to facilitate foot manipulation.

Figure 6 illustrates the B key 144 in its normal position for closing the tone opening 148. The key may be pivoted about its conventional axis 150. I provide a spring 152 which is cooperable on the arm 154 secured to the instrument and a projection 156 secured to the arm 158 for urging the key to a closed position. Key B as well as keys A and G are conventional in construction with the exception of reversing the spring tension so as to hold these keys normally closed. To the keys A, B and G I connect arms 160, 162 and 164, respectively. Figure 6 illustrates the arm 162 as being attached to its associated key 144 through the medium of screws 166. All the arms 160, 162 and 164 are identical in construction and operation so that the description of one will apply to all.

In Figure 6, the arm 162 is notched at 168 for connection with the looped end 170 of a pull line 172 passing around a grooved wheel 174 rotatably mounted on a shaft 176 in the nature of a screw connected with the channel-like support 134. Arm 162 is of such length as to bring the pull line 172 into right angular relation with the axis of the grooved wheel 174. Thus a pull on the downwardly extending run 178 of the line 172 will pivot the key 144 to an open position.

Arm 160 associated with the A key is connected with a pull line 180 passing over the grooved wheel 182 in the same manner as the pull line 172. Thus a pull on the downwardly extending run 184 of the pull line 180 will open the A key. Arm 164 is connected with a pull line 186 passing over a grooved wheel 188. A pull on the downwardly extending run 190 of the line 186 will open the valve 146. Keys A, B and G must be closed when the G tone or lower tones are played. The reversed spring action effective on these keys holds the keys closed, which keys are opened through manipulation of foot operated pedals connected with their respective pull lines.

Support 136 is associated with D, E and F keys 192, 194 and 196, respectively. Figure 7 illustrates the F key 196 as being provided with an arm 198 secured thereto by screws 200. Key 196 is changed from its conventional construction only in the provision of the arm 198, which arm is notched at 202 for connection with the loop 204 on one end of a pull line 206 which passes over a grooved wheel 208 rotatably related to the support 136 in the same manner as the wheel 174 of Figure 6. Pull line 206 includes a downwardly extending run 210 in the manner of the lines 172, 180 and 186. Key 196 is normally open and is closed by exerting a pull on the run 210. Key 194 is provided with an arm 212 connected with a pull line 214 passing over a grooved wheel

216 rotatably related to the support 136. Line 214 includes a downwardly extending run 218. Similarly, key 192 is provided with an arm 220 connected with a pull line 222 passing over a grooved wheel 224 carried by the support 136. Line 222 includes a downwardly extending run 226. Thus the keys 192, 194 and 196 may be closed by exerting a pull on their respective lines.

To the lower end of the support 136 I secure a plate 228 provided with eyelets 230 through which all the pull lines extend. Thus the plate 228 holds the lines in grouped relation and permits the lines to be pulled to an angle to the vertical beneath the plate, as indicated at 232 so as to permit the lines to be passed through eyelets in a plate 236 anchored to the base 18 considerably to one side of the grouped saxophones supported by the base. Figure 5 illustrates each line as being provided with a swivel 238 interposed in its respective line and having a threaded slack take-up 240 to permit accurate adjustment of the lines. Each swivel 238 includes a hook 242 for detachable connection with the loop 244 in one section of the divided line.

Figure 8 illustrates the arrangement of the pedals which connect with the pull lines for operating keys of the saxophone 12. Line 172 connected with the key 144 passes through an eyelet 246 in the plate 236 and is connected at 248 with an arm 250 arranged at right angles to a bar 252 pivotally journaled in bearings 254 mounted underneath the base 18. Base 18 is flanged at 256 and provided with short pads 258 so as to afford space for the rod 252 and other mechanism mounted underneath the base. Rod 252 includes a short arm 260 to which a link 262 is pivotally connected as well as with a pedal 264 pivotally connected at one end to the base 18, as at 266. An opening 268 in the base provides accommodation for the link 262. A tension spring 270 has one end connected with a screw 272 in a collar 274 secured to the rod 252 by the screw. The other end of the spring is anchored to a lug 276 fixed to the bottom face of the base 18 for exerting a rotary pull on the rod 252 for urging the arm 250 in the direction of the base 18. Thus a downward thrust on the pedal 264 will exert a pull on the line 172 for opening the key 144.

Pull line 180 associated with the key 142 passes through an eyelet 278 in the plate 236 and is connected at 280 with an arm 282 formed at one end of a rod 284 rotatably journaled in bearings 286. Rod 284 includes an arm 288 pivotally connected with a link 290 extending through an opening 294 in the base 18 for connection with the pedal 296 which is pivotally connected with the base in the same manner as pedal 264. A tension spring 298 is connected with a screw 300 carried by a collar 302 fixed to the rod 284 by the screw. The opposite end of the spring is hooked into a lug 304 attached to the base 18 for rotating the rod 284 to move the arm 282 in the direction of the base 18. Thus downward pressure on the pedal 296 will move the arm 282 for exerting a pull on the line 180 for opening the valve 142. Line 186 passes through an eyelet 305 in the plate 236 and is connected at 306 with an arm 308 carried by a rod 310 rotatably journaled in bearings 312. An arm 314 is formed at one end of the rod 310 and is pivotally connected with a link 316 extending through an opening 318 in the base 18 for connection with the pedal 320. One end of a tension spring 322 is connected with a set screw 324 in a collar 326 fixed to the rod 310 by the set screw. The opposite end of the spring 322 is connected

with a lug 328 attached to the base 18. Spring 322 exerts a rotary pull on the rod 310 for urging the arm 308 in the direction of the base 18. Arm 308 is bent to extend underneath the arm 250, as at 330, while the arm 282 is bent to extend over the arm 308, as at 332.

With the keys 142, 144 and 146 closed, the tone produced is G. To produce the tone A, the key 146 alone is opened through pressure on the pedal 320. To play the tone B, both keys 142 and 146 are opened. This may be accomplished by pressing the pedal 296 alone, since the arm 282 will press down on the arm 308 so that both keys will be opened. To play the tone C, the keys 144 and 146 are opened, with the key 142 remaining closed. This is accomplished by pressing down on the pedal 264 alone. Movement of the arm 250 will exert pressure on the arm 308 for opening the valve 146 also, with the valve 142 remaining closed. To make the tone C#, all three keys 142, 144 and 146 must be opened. This is accomplished by pressing down on the pedal 246 with the toe and down on the pedal 264 with the heel of that foot. Both arms 250 and 282 extend underneath the arm 308 so that the latter will be pressed down simultaneously with the other two keys.

Arms 260, 288 and 314 may be provided with stops 334 for engaging the bottom face of the base 18 to accurately position the associated line pulling arms. The stops may comprise screws having threaded relation with their respective arms. It is advisable to provide each screw with padding for engagement with the base 18 to dampen the sound.

Pull line 222 associated with the key 192 passes through the eyelet 336 in the plate 236 and is connected at 338 with an arm 340 connected at right angles with a rod 342 rotatably journaled in bearings 344. Rod 342 includes an arm 346 pivotally connected with a link 348 extending through an opening 350 in the base 18 for connection with the pedal 352. One end of a tension spring 354 is connected with a set screw 356 carried by a collar 358 secured to the rod 342 by the set screw. The other end of the spring 354 is connected with a lug 360 attached to the base 18 for rotating the rod 342 to move the arm 346 in the direction of the base. Thus the key 192 may be closed by exerting a pull on the line 222 through the medium of the pedal 352.

The line 214 connected with the key 194 passes through the eyelet 362 in the plate 236 and is connected at 364 with an arm 366 carried by a rod 368 rotatably journaled in bearings 370 attached to the base 18. Rod 368 is provided with an arm 372 pivotally connected with a link 374 extending through an opening 376 in the base 18 for connection with the pedal 378. Arm 372 is urged in the direction of the base 18 through the medium of a tension spring 380 having one end connected with the set screw 382 carried by the collar 384 secured to the rod 368 by the set screw. A lug 386 is attached to the base 18 and is connected with the other end of the spring 380 for holding the latter under tension so that the spring tension will urge the arm 372 in the direction of the base 18.

The pull line 206 associated with the key 196 passes through the eyelet 388 in the plate 236 and is connected at 390 with an arm 392 attached to the rod 394 rotatably journaled in bearings 396 attached to the base 18. I pivotally connect the arm 398 with the link 400 similarly connected with the pedal 402. Arm 398 is urged in the

direction of the base 18 through the medium of a tension spring 404 connected with the set screw 406 carried by the collar 408 made secure to the rod 394 by the set screw. Spring 404 is hooked into a lug 410 attached to the base 18.

Normally open keys must be closed securely to avoid a leak. Too much closing pressure will cut the pad covering. In connection with the foot operation of the normally open keys 192, 194 and 196, the arms 340, 366 and 392 comprise flat spring material. When the pedals associated with these spring arms are pressed, the arms pivot far enough to assure effective closing of the associated keys, but the tension of the spring arms is such as to permit the arms to yield at the moment that the keys have been closed sufficiently secure. Thus the tension of the spring arms is such as to relieve the key or pad covering from damage incident to excessive closing pressure. Pull lines 266, 214 and 222 require no slack in the open positions of the associated keys. The arms 346, 372 and 398 are provided with stops 412 corresponding to the stops 334. These stops are adjusted so as to stop the upward movement of the associated arms immediately before their respective keys are completely open. Thus the spring tension of the conventional springs associated with the keys holds the lines sufficiently taut.

In connection with normally closed keys, it is essential that the pull lines be so adjusted with the keys at rest as not to restrain the keys from complete closing. The keys must be securely closed so as to prevent leaks. It is, therefore, essential that the associated pull lines must embody a certain degree of slack, but the slack must be limited so as to prevent the lines from jumping their associated grooved wheels.

With reference to the keys 142, 144 and 146, Figure 13 illustrates a slack take-up which may be provided for each of the arms 248, 282 and 308. Pull lines 172, 180 and 186 may be utilized without slack take-up means but operation under such conditions requires considerable adjustment. Figure 13 illustrates the manner in which arm 250, as an example, may be provided with a weak, flat spring 414 for taking up slack in the line 172. One end of the spring 414 is fixedly connected at 415 with the arm 250, and the arm is bored at 418 for loosely receiving the line. The end of the line is provided with a ball 420 which lies underneath the flat spring 414 and is fixedly connected with the line. The spring is bored for the reception of the line. Figure 13 illustrates the arm 250 in its normal position at which time the key 144 is closed. Spring 414 bears against the ball 420 for placing the line 172 under the necessary tension. When the pedal 264 associated with the line 172 is pressed down, resistance offered by the key 144 will flex the spring 414 against the arm 250 after which the arm pressure exerts a pull on the line 172 for opening the key. In the normal position of Figure 13, spring 414 exerts sufficient pressure on the line 172 to effectively hold the key 144 in closed position, but the pressure is slight so as not to open the key.

Figure 5 illustrates an arm 422 as being connected with the shaft 424 which operates the G# key 426. To the outer end of the arm 422 I connect a pull line 428 which is passed over one of the usual key guard bars 430 and extended downwardly for passage through the eyelet 432 in the plate 236. Pull line 428 is connected at 434 with an arm 436 carried by a rod

438 rotatably journaled in bearings 440. Rod 438 includes an arm 442 pivotally connected with a link 444 extending through an opening 446 in the base 18 for pivotal connection with the pedal 448. Thus the normally closed G# key 426 may be opened by exerting a pull on the line 428 through pressing down on the pedal 448.

I connect a tension spring 450 with a lug 452 attached to the base 18 and with a set screw 454 carried by a collar 456 attached to the rod 438 by the set screw. Spring 450 urges the arm 442 in the direction of the base 18, and the arm is provided with a stop 458 corresponding to the stops 334.

In Figure 14, I illustrate the button 460 which is utilized for finger manipulation of the octave key (not shown) associated with the saxophone 12. Button 460 is connected with the shaft 462 in the usual manner. To the saxophone 12 I connect a bracket 464 (see Fig. 14) which carries a grooved wheel 466. To the button 460 I connect a pull line 468 which passes over the grooved wheel 466 and downwardly through an eyelet 469 attached to the support 134, then through a perforation in the plate 228 and through the eyelet 470 in the flange 20 and a similar opening in the base 18 for connection at 472 with an arm 474 of a rod 476 rotatably journaled in bearings 478. Rod 476 is provided with an arm 480 which is pivotally connected with a link 482 extending through the opening 484 in the base 18 for connection with the pedal 486.

I connect one end of a tension spring 488 with a lug 490 attached to the base 18, and the other end of the spring is connected with a set screw 492 carried by a collar 494 secured to the rod 476 by the set screw. Spring 488 moves the arm 474 in the direction of the base, and this arm may be provided with a stop 496 corresponding to the stops 334.

It will be noted that the tension spring associated with each of the rods 252, 294, 310, 342, 368, 394, 438 and 476 is connected with its respective rod adjacent one of the supporting bearings for that rod. The tension spring operates to eliminate rattling between its respective rod and the associated bearing in addition to placing the rod under rotary tension. Each of these rods is provided with a small tension spring connected with that rod adjacent the opposite bearing to prevent rattling of the rod in the event of a loose fit.

Figure 9 illustrates a tension spring 498 as having one end connected with the set screw 500 in the collar 502 secured to the rod by the set screw. The opposite end of the spring is hooked over a pin 504 fixed to the base 18. In connection with the rod 284, a tension spring 506 is connected with the rod in the same manner as the spring 498 and is hooked over the pin 504. A tension spring 508 is connected with the rod 310 in the same manner as the spring 498 and is hooked over the pin 504. Rod 342 is provided with a tension spring 510 connected with the rod in the same manner as the spring 498 and is hooked over a pin 512 anchored to the base 18. A spring 514 is hooked over a pin 516 anchored to the base 18 and connected with the shaft 368 in the same manner as the spring 498. Rod 394 is connected with a spring 518 in the same manner as the spring 498 and is hooked over a pin 520 anchored to the base 18. Spring 522 is hooked over a pin 524 anchored to the base 18 and connected with the rod 438 in the same manner as the spring 498. Similarly, rod 476

is connected with a spring 526 hooked over a pin 528 and connected with the rod in the same manner as the spring 498.

I claim:

5 1. A device of the type described comprising a support, right, center and left wind-blown instruments mounted on said support, each instrument having a mouthpiece and the instruments converging one with the other to group the
10 mouthpieces for coaction with a common source of wind, the right instrument being provided with keys located for right hand manipulation thereof along the right side of the instrument,
15 the left instrument being provided with keys located for left hand manipulation thereof along the left side of the instrument, foot operated elements, said center instrument having keys,
20 and operating connections between the keys of the center instrument and said foot operated elements.

2. A device of the type described comprising a support, right, center and left wind-blown instruments mounted on said support, each instrument having a mouthpiece and the instruments converging one with the other to group
25 the mouthpieces for coaction with a common source of wind, the right instrument being provided with keys located for right hand manipulation thereof along the right side of the instrument, the left instrument being provided with
30 keys located for left hand manipulation thereof along the left side of the instrument, foot operated elements, said center instrument having keys, pull lines connecting the keys of the center
35 instrument with said foot operated elements, and yielding tensioning means coacting with said pull lines and their respective foot operated elements for maintaining the pull lines taut, but yielding upon partial actuation of the foot operated elements for establishing unyielding connections between the pull lines and their respective
40 foot operated elements.

3. The combination of a standard, right, center and left saxophones mounted on said standard,

each saxophone having a mouthpiece and the saxophones being supported on the standard to group the mouthpieces for coaction with a common source of wind, the right saxophone being provided with keys located for right hand manipulation thereof along the right side of the
5 instrument, the left instrument being provided with keys located for left hand manipulation thereof along the left side of the instrument, foot operated elements, biased rockable members housed inside said base, said center saxophone
10 having keys, pull lines connecting the keys of the center saxophone with said rockable members, pressure elements operatively connected with said biased rockable members and extending through openings in the base for foot
15 manipulation thereof, a pull line grouping member secured to the center saxophone for closely grouping the pull lines, and a pull line grouping means attached to said base for closely grouping
20 the pull lines exteriorly of the base.

4. The combination of a standard means, a cross member on said standard means, three arms pivotally and adjustably connected with said cross member, a right saxophone having a universal connection with one of said arms, a center
25 saxophone having a universal connection with the second arm, a left saxophone having a universal connection with the third arm, each saxophone having a mouthpiece and the saxophones being supported by said arms with said mouthpieces grouped for coaction with a common
30 source of wind, the right saxophone being provided with keys located for right hand manipulation thereof along the right side of the instrument, the left saxophone being provided with keys located for left hand manipulation thereof along the left side of the instrument, foot operated elements, said center saxophone having
35 keys, and operating connections between the keys of the center saxophone and said foot operated elements.

BILL G. TREW.